

Efficient Branched History Management Based on History Segmentation

DoHyoung Kim, Frank M. Shipman III

Department of Computer Science and Center for the Study of Digital Libraries

Texas A&M University

College Station, TX 77843-3112 USA

+1 979 845 3839

kim, shipman@cs.tamu.edu

ABSTRACT

An inherent characteristic of most forms of spatial hypertext expression is ambiguity. History has been added to some spatial hypertext systems to aid in comprehension of ambiguous expressions. This paper describes how to manage multiple versions of a spatial hypertext by splitting its branched history into segments. Additionally, this history management scheme reduces the amount of branching/grouping information stored separate from the chronologically-ordered linear event history. This scheme is implemented in the Visual Knowledge Builder, and the prototype of the interface for manipulating the history is currently in progress.

Keywords

spatial hypertext, history, information visualization

1. INTRODUCTION

The need for emergent expression was a characteristic of the driving tasks and activities that resulted in the development of the first spatial hypertext systems. Placing items visually allowed people to quickly modify their expressions yet also provided ambiguity so they could indicate the degree of belief or confidence in connections among elements. Along with this constructive use of ambiguity, the evolution of spatial hypertexts resulting in ambiguities unintended by author(s).

The Visual Knowledge Builder (VKB) added a history mechanism such that users could rewind and replay the editing actions that resulted in the spatial hypertext [3]. This presentation of a document's creation can help readers understand authors' work practices by facilitating their recognition of patterns of activity and by clarifying specific actions and content in the information space [2].

Although the reported VKB history mechanism allows users to navigate a document in time dimension, the users cannot make modifications at earlier times without losing all edits subsequent to that state in the document's history.

To alleviate this problem, a new history mechanism has been developed in order to provide branching history. Other systems have included branching history. The *Designers' Outpost* system displays only active history as a linear list of events, and hides inactive history branches by representing them as collapsed stubs which are used by users to reach another history branch [1]. *Footprints* provides site map and path map that show the history of past users' work, so that users can get hints from the maps to

solve problems [4]. However, publications on these projects do not present how to manage the branching history information efficiently, limiting their scope application-specific visualization techniques. With some VKB documents containing thousands of edits over periods of years, we need to consider efficiency in our representation and management of branched history.

2. DESIGN

The new VKB history mechanism is designed to construct and traverse the branched history of a document and to maintain grouping information among history events. This scheme introduces a *segment*, a chunk of continuous history events in chronological order. Segments are contiguous history events that enable efficient interaction with the branched history.

In addition to segments, the VKB history mechanism supports user-defined history *groups* that are used to represent activities (such as a particular discussion or design task). Segment and group tables use minimal memory and do not affect the existing history structure in VKB. While a branching action logically occurs in the past, chronologically it occurs in the present, the history representation much maintain both chronological and logical history structures. Therefore, a segment and group representation was developed to separate the representation of the branching and grouping from the chronologically ordered history event list.

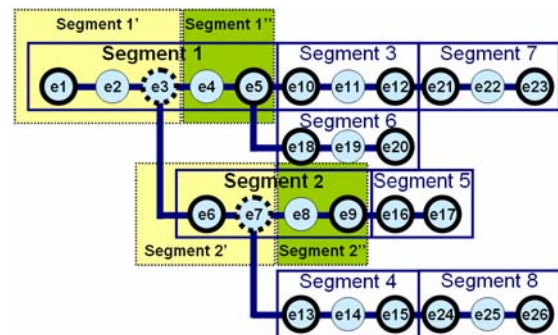

Figure 1. Branched history with segmentation

2.1 Segments

A segment is a series of history events. It is formed when a history event occurs that is not logically in order with the previous chronological event. There are two ways for this to occur. An edit that occurs at a prior state of the document results in a new branch. For example, in Figure 1, the 6th event (e6) causes a

new segment (segment 2) to be created to represent the new branch and divides the existing segment (segment 1) into two segments (segments 1' and 1''). Segments are also created for continuations of an existing branch. For example, the 10th event (e10) in Figure 1 causes the formation of segment 3 as the author came back to the end of the first version of the document (segment 1'') after editing the version at segment 2.

The segment table maintains the branched history that is used to build and track different versions of a document. The segment table in Table 1 shows the segment table constructed for the branched history in Figure 1. In the table, "Previous Segment" identifies the logically previous segment for the new segment. When an event branches in the middle of an existing segment, that segment is split into two segments. "Start / End Event" sections indicate the first and the last event of a segment. Therefore, the segment table must be updated whenever a history event occurs.

Table 1. Segment table (left) / Group table (right)

| Segment Table | | | | Group Table | | | |
|---------------|------------------|-------------|-----------|-------------|-------------|-----------|--------------|
| Segment | Previous Segment | Start Event | End Event | Group | Start Event | End Event | Last Segment |
| 1 → 1' | Root | 1 | 5 → 3 | A | 5 | 19 | 6 |
| 1'' | 1' | 4 | 5 | B | 4 | 11 | 3 |
| 2 → 2' | 1'' | 6 | 9 → 7 | C | 2 | 21 | 7 |
| 3 | 1'' | 10 | 12 | D | 3 | 13 | 4 |
| 2'' | 2' | 8 | 9 | E | 3 | 4 | 1' |
| 4 | 2'' | 13 | 15 | | | | |
| 5 | 2'' | 16 | 17 | | | | |
| 6 | 1'' | 18 | 20 | | | | |
| 7 | 3 | 21 | 23 | | | | |
| 8 | 4 | 24 | 26 | | | | |

(→ : update)

2.2 Groups

As previously mentioned, users can group events to help others understand the document. The history mechanism includes a group table (see Table 1) to maintain the start/end event of a group to measure its boundaries. The group table also includes the segment where the last event in the group is included in order to quickly identify which version(s) of a document include a particular group. For example, "Group A" in Figure 2 is only part of the logical versions of the document that includes segment 6.

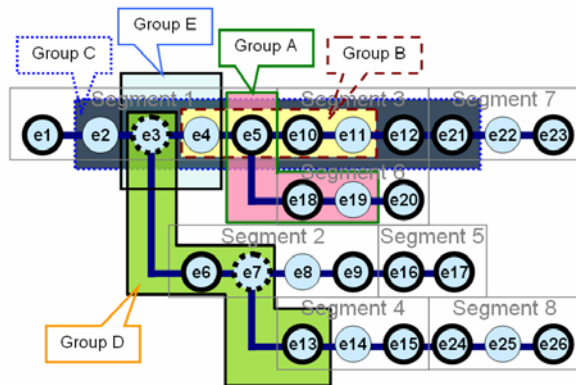

Figure 2. Branched history with group information

3. VISUALIZATIONS

Visualizations are being developed based on the branched history representation included in the segment and the group tables. Two visualizations are included in the current prototype (see Figure 3). Both the chronological time-driven visualization and the logical event-driven visualization also provide for navigation between different versions of a document.

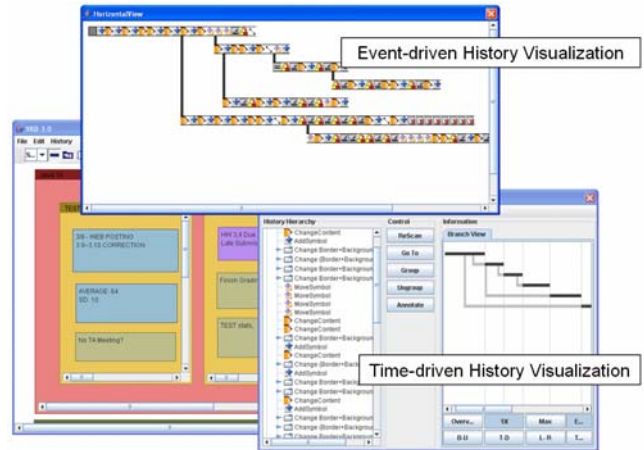

Figure 3. History visualization tool (prototype)

4. DISCUSSION

The new VKB history mechanism includes support for branching history with large numbers of edit events. The use of segment and group tables provides an efficient representation separating the branching information of a document history from the chronological list of edit events while continuing to allow user-defined event groups. This representation was evaluated based on five different usage scenarios in order to ensure its validity with a variety of usage patterns.

Interfaces for navigating and manipulating the branching history are being developed. Alternative visualizations of the branching history are being considered to facilitate user comprehension of the document history and to prevent user disorientation when navigating between the multiple versions of a document.

5. REFERENCES

- [1] S. Klemmer, M. Thomsen, E. Phelps-Goodman, R. Lee, and J. Landay. Where Do Web Sites Come From?: Capturing and Interacting with Design History. *Proc. of the SIGCHI Conference on Human Factors in Computing*, 2002, pp. 1-8.
- [2] F. Shipman and H. Hsieh, "Navigable History: A Reader's View of Writer's Time", *New Review of Hypermedia and Multimedia*, Vol. 6 (2000), pp. 147-167.
- [3] F. Shipman, H. Hsieh, R. Airhart, P. Maloor, and J.M. Moore. The Visual Knowledge Builder: A Second Generation Spatial Hypertext. *Proc. of the ACM Conference on Hypertext*, 2001, pp. 113-122.
- [4] A. Wexelblat and P. Maes. Footprints: History-Rich Tools for Information Foraging. *Proc. of the SIGCHI Conference on Human Factors in Computing (CHI'99)*, 1999, pp. 270-277.